



brewer science
Where innovation takes flight!SM

InFlect™ Thermistor

Brewer Science InFlect™ thermistors utilize our revolutionary carbon-based nanotechnology to deliver accurate and real-time response to small changes in temperature.

BENEFITS

- Millisecond data capture for enhanced yield and throughput
- Extends battery life due to low-power operation
- Improves decision-making capabilities through real-time data collection
- Easily interfaces to existing electronic systems



FEATURES

- Ultrafast response time (< 250 ms)
- Low-power operation (< 30 pW)
- Wide operating voltage range (< 4 mV - 50 V)
- Hermetically sealed; environmentally stable
- Low drift; high accuracy
- Flexible form factor

APPLICATIONS

- Industrial tool optimization
- Temperature monitoring of electronic components
- Environmental monitoring
- Personal electronics/wearables
- Food/agricultural supply chain and storage
- Consumer appliances
- Power supply (heat sinks)
- Battery, displays, LED
- Robotics
- EV and HV batteries

SPECIFICATIONS

The specifications are for standard thermistors. The dimension, form factor, and performance specifications can be customized to meet application requirements.

Parameter	Performance	Unit
Resistance value (25°C)	500	kΩ
Resistance tolerance (25°C)	±10	%
Accuracy (20°C to 90°C, linear fit)	< 2.2	°C
Hysteresis	< 2.0	°C
Linearity (20°C to 90°C)	< 0.2	%
Temperature resolution	0.25	°C
Sensitivity (20°C to 90°C)*	-3400 ± 100	ppm
Thermal time constant (1/e)	< 250	ms
Device stability (Drift in R): (25°C, 50% RH, 100 hours) (85°C, 85% RH, 100 hours)	< ± 0.7 < ± 1.0	%
Minimum operating power (< 4 mV, < 8 nA)	< 30	pW
I-V linearity	± 50	V
Operating temperature**	-20 to 100	°C
Operating humidity	0 to 85	%
RH dependency (25% to 85%, 25°C)	< 0.2	°C
Bend correction (25°C)	< 0.041	°C/degree bend

* Sensitivity= 2.1/1.9/2.3 kΩ/°C for 500/450/550 kΩ thermistors

** Hysteresis and accuracy values can be as high as 6°C and 4°C respectively in the (-20°C, +100°C) range, and 4°C and 3°C in the (-10°C, +100°C) range.

THERMISTOR DIMENSIONS

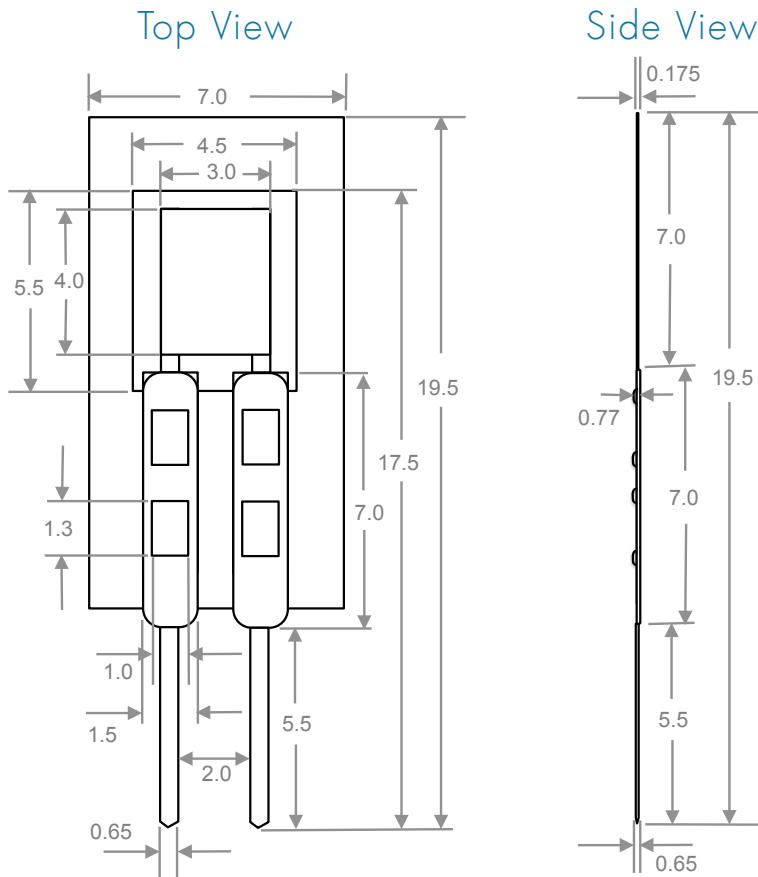

Figure: A schematic of Brewer Science's thermistor in millimeters

Parameter	Specification
Sensor dimension	7 x 19 mm
Sensing region dimension	2 x 3 mm
Weight including connecting pins	92 mg
Weight without connecting pins	17 mg
Storage temperature	10-35°C
Storage condition	10-55% RH
Shelf life	> 12 months

Mounting and Electrical

- The thermistor comes with 0.1" (2.54 mm) pitch crimp pins
- The thermistor is available in FFC connection type for slide-in connection
- Maximum supply voltage = 50 V
- Maximum power dissipation (5 V, 25°C) = 50 μ W

SENSOR CUSTOMIZATION

- Dimensions and form factor of the sensors can be customized to meet application requirements.
- The sensor can be fabricated on a large variety of substrates depending upon the applications requirements.

THERMISTOR OUTPUT CHARACTERISTICS

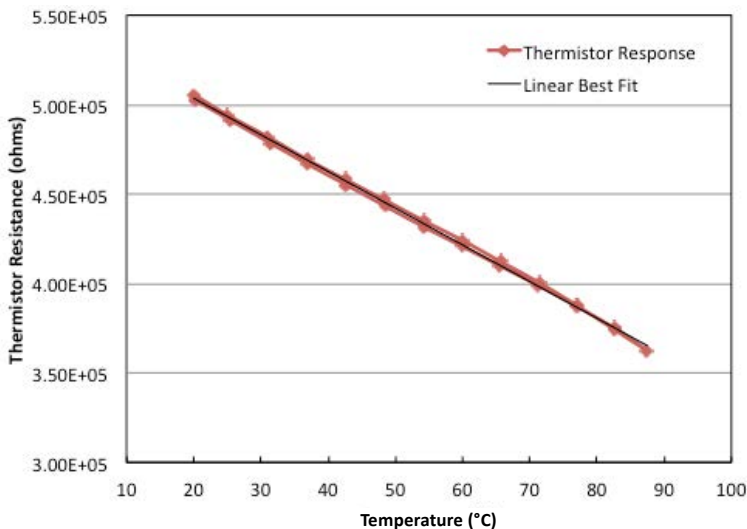

Figure: Thermistor resistance output vs. temperature curve (At 35% RH and V=0.5 V).

© 2017 Brewer Science, Inc.

All statements, technical information, and recommendations contained herein are based on tests we believe to be accurate, but the accuracy or completeness thereof is not guaranteed and the following is made in lieu of warranty expressed or implied. Neither the seller nor the manufacturer shall be liable for any injury, loss, or damage, direct or consequential, arising from the use or inability to use the product. Before using, user shall determine the suitability of the product for his intended use, and user assumes all risk and liability whatsoever in connection therewith. No statement or recommendation contained herein shall have any force or effect unless in an agreement signed by officers of the seller and manufacturer.

Effective Date: 5/12/2017