



brewer science

Where innovation takes flightSM

Cee[®] X-Pro II Workstation

Capturing Evolution In One Machine

The Cee[®] X-Pro II workstation creates its own mini-environment that houses your customized solution all in one place. The workstation is completely customizable and can accommodate any process.

The Cee[®] X-Pro II mini-environment offers versatility in combination with our Cee[®] benchtop equipment offerings. This package will decrease the complexity of installation with a "plug-and-play" setup and provide value to the customer through a "one-stop-shop" solution.

BENEFITS

- Environment monitoring
- Ease of installation & access
- Variety in usability
- A robust solution: workstation, tools, and service/installation

FEATURES

- Customizable configuration
 - Four 200-mm modules
 - Two 300-mm modules
 - Two 200-mm and one 300-mm modules
- Choice of HEPA filtration with optional climate control, or updraft hood exhaust
- Temperature and humidity monitoring system, 79" x 35" maximum dimensions



Coat



Bake



Develop

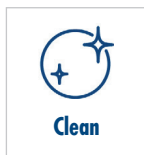

Clean

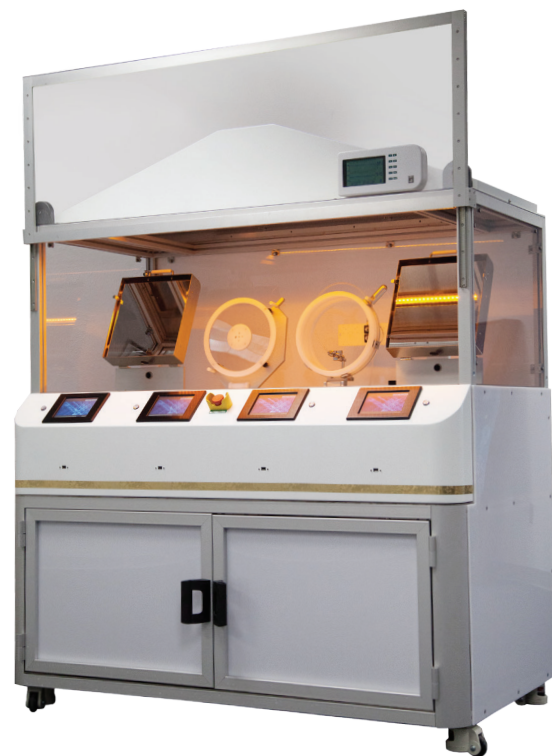
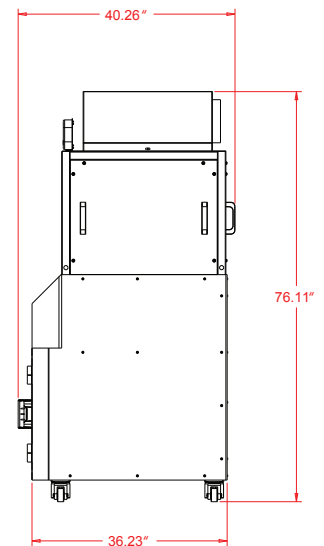
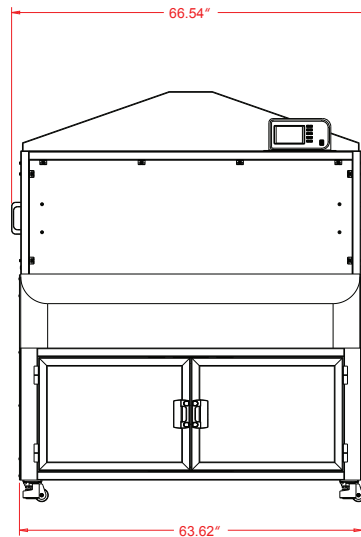

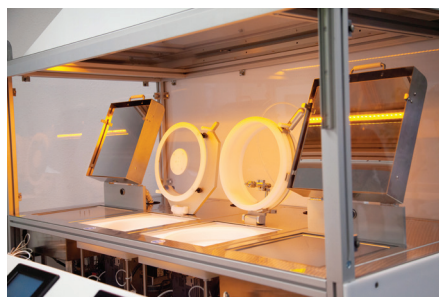

© 2016 Brewer Science, Inc.

All statements, technical information, and recommendations contained herein are based on tests we believe to be accurate, but the accuracy or completeness thereof is not guaranteed and the following is made in lieu of warranty expressed or implied. Neither the seller nor the manufacturer shall be liable for any injury, loss, or damage, direct or consequential, arising from the use or inability to use the product. Before using, user shall determine the suitability of the product for his intended use, and user assumes all risk and liability whatsoever in connection therewith. No statement or recommendation contained herein shall have any force or effect unless in an agreement signed by officers of the seller and manufacturer.

Effective Date: 2/4/2016